



## Rotary-hydraulic drilling rigs - URB types

### Purpose of use

Drilling rig URB-40 is designed for drilling and repairing of industrial water supply wells; technical wells building, including for degasification, ventilation, water level lowering purposes; wells for the inside laying communications into the underground mining; hydrogeological exploration and underground leaching.

### Technical characteristics:

Chassis	URAL 4320, semitruck, etc.
Power take off box	100% power take off
Power take off capacity, kW	130
Max. hook load, kN(tf)	392 (40)
Drilling depth, m	1000
Drilling pipes diameter, mm	73 / 89 / 114
Recommended drilling diameter, mm (initial/final)	780 / 190,5
Winch drive	Drive from the main engine through PTO, cardan drive shaft, gearbox, transfer box
Gearbox	3-speed with electro-pneumatic operator
Gearbox speed ratio	-2,43 / -1,2 / -0,6
<b>Drilling winch (drawwork)</b>	2-reels, with central conical transfer box and planetary transfer box inside the drums. Strips up/down brake on the every two drums
Towing winch capacity on the 2-nd winding coil of the rope on the reel, kN (tf)	73,858 (7,5)
Rope reel winding speed with 1400 r/min main engine rotation depending of the gearbox speed ratio turn on, m/s	1,4 -5,7
Hoist-swivel - feed pipe - (4-string polyspast with 2x3 ratio) lifting speed depending of the gearbox speed ratio turn on, m/s	0,35 — 1,4
Hoist — up/down elevator - (6-string polyspast with 3x4 ration) lifting speed depending of the gearbox speed ratio turn on, m/s	0,23 — 0,95

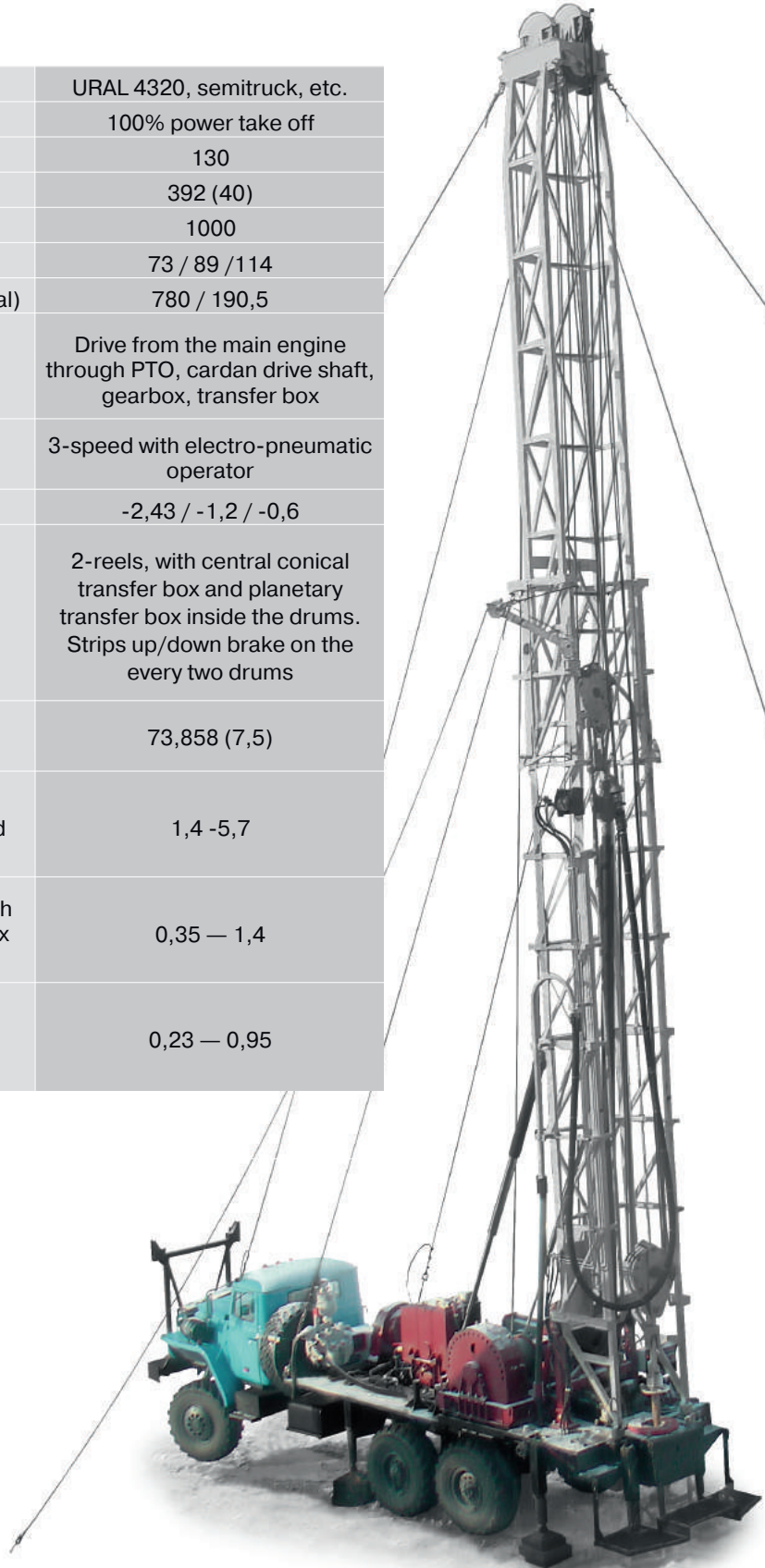

# Rotary-hydraulic drilling rigs - URB types

<b>Rotor</b>	RG-425 hydrodriving with hydraulic offtake from the well head
Max. torque kNm (kgfm)	15,96 (1600)
Rotation frequency of the rotation table (r/min)	0-180
Number of the driving speed, provided by the hydraulic scheme	9
<b>Auxiliary winch with the tilt faucet</b>	Hydraulic
Auxiliary winch towing capacity, kN(tf)	21,56 (2,2)
<b>Feeding pipe</b>	Round cross-section with guidelines
Feeding pipe diameter, mm	114
Feeding pipe length, m	7
<b>Mast</b>	Originally constructed with the open front flat, telescopic, vertical
Distance from the rotary table to the crown block axis, m, no more	17,8
Distance from the soil to the crown block axis, m, no more, m	19,3
Drilling pipe length, m	6/12
Distance of the setting pipe, m	12
<b>Crown block</b>	separated
- for the hoist block with the feeding pipe	
Polyspast ratio	2x3, 4-strips mounting
Polyspast payload, kN (tf)	294,3(30)
- for the hoist block hoisting and drilling load cycles	
Polyspast ratio	3x4, 6-strips mounting
Polyspast payload, kN (tf)	392 (40)
Well bottom weight and load control system	ИВЭ-50
<b>Swivel</b>	
Allowed load, kN(tf)	294 (30)
Diameter of the swivel's hole, mm	60
<b>Drilling pump</b>	НБ-50
Max. ideal feeding, m <sup>3</sup> /h (l/s)	39,6 (11)
Max. exit pressure, MPa (kg/sm <sup>2</sup> )	6,3 (63)
<b>Overall dimensions (transport), mm</b>	
- length/width/height	12500/2500/4000
Overall drilling rig weight, kg	23100



## Additional options

- 16 kW electric generator
- Pump dispenser PAV
- A set of equipment/tools for drilling with reverse water circulation
- Manifold for the additional equipment connection (drilling pump, compressor).



Drilling rig URB-40 onto the URAL-4320 chassis

Implemented drilling methods	Max. diameter, mm
Rotary non-core with water circulation	up to 780
DTH	up to 680
Shock and rotary non-core with reverse airflush (by RC technology)	up to 380
With reverse water circulation (air lift technology)	up to 1000

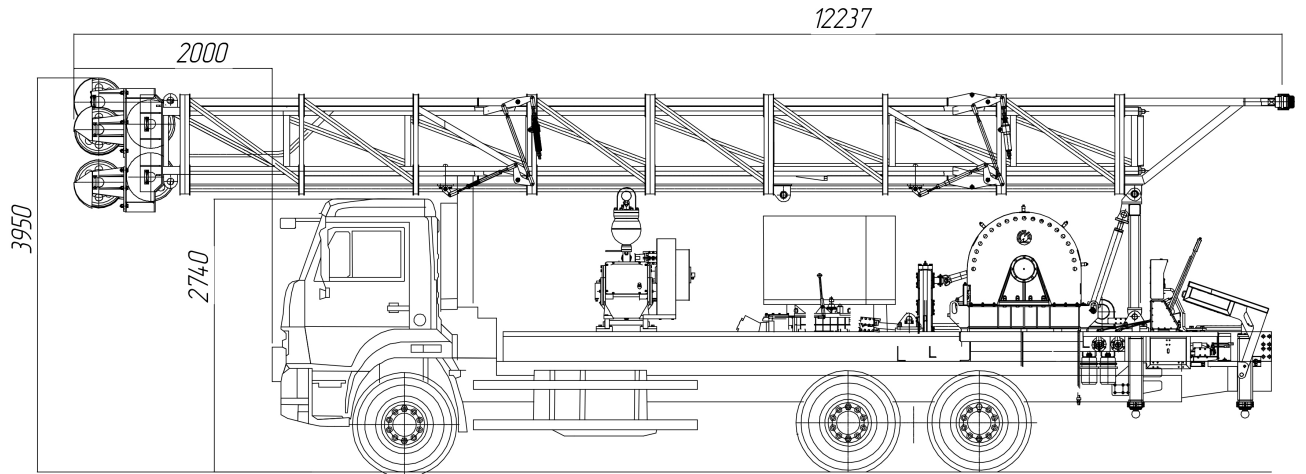

Drilling rig URB-40 onto the KAMAZ 65115-3094-48 chassis

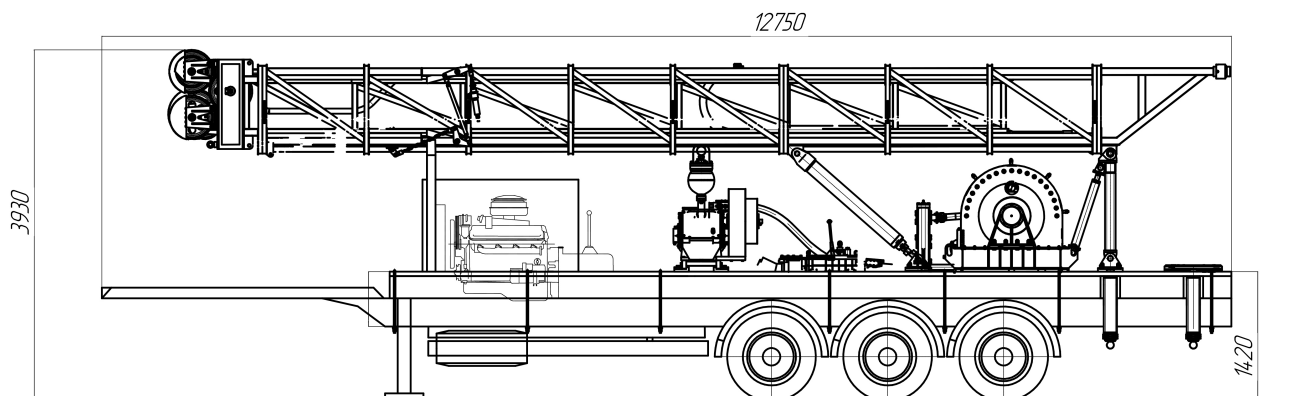

Drilling rig equipment URB-40 onto the  
ЧМ3АП-9911.000000.053-PW container semi-trailer

**For equipment purchase and  
additional information:**

«Geomash-Centre»  
Russia, 121351, Moscow,  
Kuntsevskaya st, 9/2  
+7 (495) 902-55-20  
[www.geomash.ru/en/](http://www.geomash.ru/en/)